

IMB25

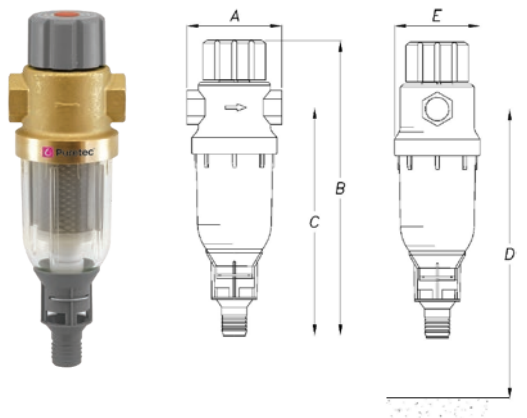

IMB50

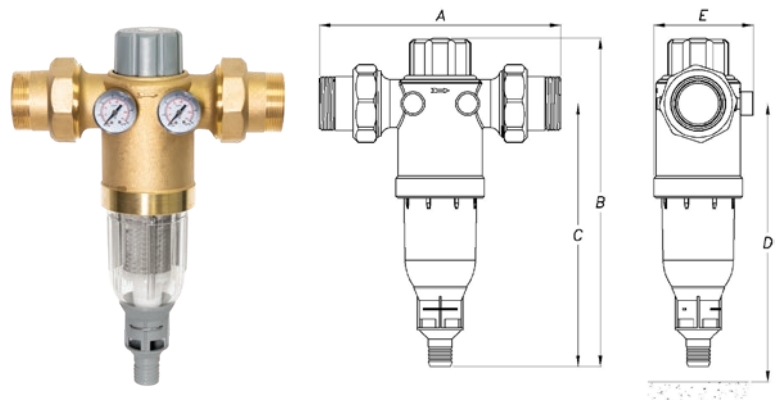

Model	A	B	C	D	E
IMB25	100	310	240	400 min	100
IMB50	265	361	289	400 min	109

GENERAL INFO

DESIGNED FOR INDUSTRIAL & COMMERCIAL APPLICATION

Manual Backwash Water Filter Systems

Puretec IMB Series is an innovative filter with a patented system of cleaning composed by two different actions: brushing of the filtering cartridge and high speed discharge. This method allows an efficient and thorough cleaning both of the filtering cartridge and the filter bowl.

The cleaning is started by rotating clockwise the upper grey knob: this movement activates, at each click, the brushing system and the opening of the discharge valve which creates an high speed tangential flow which removes impurities accumulated in the filter bowl.

SPECIFICATIONS

Models:	IMB25	IMB50
Micron Rating	89	89
Connection	1"	2"
Service Flow Lpm	75	200
Max Flow Lpm	90	216
Min/Max Pressure	150 kPa - 1600 kPa	
Min/Max Temperature	0°C - 30°C*	
Warranty	1 Year Warranty^	

FEATURES & BENEFITS

- Stainless steel net filtering surface is resistant to mechanical shock and pressure gradients.
- Cleaning brushes are equipped with silver to inhibit bacterial growth.
- Standard 89um screen.
- IMB50 is equipped with twin pressure gauges to monitor pressure drop.
- High strength discharge valve.
- Brass head

**1 year replacement parts and labour. *Protect from freezing.*